

## Ceiling Mounted Built-in Type

Model		FXSQ40MVE	FXSQ50MVE	FXSQ63MVE	
★1 Cooling Capacity (19.5°CWB)	kcal/h	4,000	5,000	6,300	
	Btu/h	15,900	19,900	25,000	
	kW	4.7	5.8	7.3	
★2 Cooling Capacity (19.0°CWB)	kW	4.5	5.6	7.1	
★3 Heating Capacity	kcal/h	4,300	5,400	6,900	
	Btu/h	17,000	21,500	27,300	
	kW	5.0	6.3	8.0	
Casing		Galvanized Steel Plate	Galvanized Steel Plate	Galvanized Steel Plate	
Dimensions: (H×W×D)		mm	300×700×800	300×700×800	300×1,000×800
Coil (Cross Fin Coil)	Rows×Stages×Fin Pitch	mm	3×14×1.75	3×14×1.75	3×14×1.75
	Face Area	m <sup>2</sup>	0.132	0.132	0.221
Fan	Model		D18H2A	D18H2A	2D18H2A
	Type		Sirocco Fan	Sirocco Fan	Sirocco Fan
	Motor Output × Number of Units	W	65×1	85×1	125×1
	Air Flow Rate (H/L)	m <sup>3</sup> /min	11.5/9	15/11	21/15.5
	★4 Static external pressure	Pa	88-49-20	88-59-29	88-49-20
	Drive		Direct Drive	Direct Drive	Direct Drive
Temperature Control		Microprocessor Thermostat for Cooling and Heating	Microprocessor Thermostat for Cooling and Heating	Microprocessor Thermostat for Cooling and Heating	
Sound Absorbing Thermal Insulation Material		Glass Fiber	Glass Fiber	Glass Fiber	
Air Filter		Resin Net (with Mold Resistant)	Resin Net (with Mold Resistant)	Resin Net (with Mold Resistant)	
Piping Connections	Liquid Pipes	mm	φ6.4 (Flare Connection)	φ6.4 (Flare Connection)	φ9.5 (Flare Connection)
	Gas Pipes	mm	φ12.7 (Flare Connection)	φ12.7 (Flare Connection)	φ15.9 (Flare Connection)
	Drain Pipe	mm	VP25 (External Dia. 32 Internal Dia. 25)	VP25 (External Dia. 32 Internal Dia. 25)	VP25 (External Dia. 32 Internal Dia. 25)
Machine Weight	kg	30	31	41	
★6 Sound Level (H/L)	dBA	38/32	41/36	42/35	
Safety Devices		Fuse, Thermal Protector for Fan Motor	Fuse, Thermal Protector for Fan Motor	Fuse, Thermal Protector for Fan Motor	
Refrigerant Control		Electronic Expansion Valve	Electronic Expansion Valve	Electronic Expansion Valve	
Connectable outdoor unit		R410A M Series	R410A M Series	R410A M Series	
Decoration Panel (Option)	Model		BYBS45DJW1	BYBS45DJW1	BYBS71DJW1
	Panel Color		White (10Y9/0.5)	White (10Y9/0.5)	White (10Y9/0.5)
	Dimensions: (H×W×D)	mm	55×800×500	55×800×500	55×1,100×500
	Weight	kg	3.5	3.5	4.5
Standard Accessories		Operation Manual, Installation Manual, Paper Pattern for Installation, Drain Hose, Clamp Metal, Insulation for Fitting, Sealing Pads, Clamps, Screws, Washers.	Operation Manual, Installation Manual, Paper Pattern for Installation, Drain Hose, Clamp Metal, Insulation for Fitting, Sealing Pads, Clamps, Screws, Washers.	Operation Manual, Installation Manual, Paper Pattern for Installation, Drain Hose, Clamp Metal, Insulation for Fitting, Sealing Pads, Clamps, Screws, Washers.	
Drawing No.		3D039431			

## Notes:

- ★1 Indoor temp. : 27°CDB, 19.5°CWB / outdoor temp.: 35°CDB / Equivalent piping length: 7.5m, level difference: 0m.
- ★2 Indoor temp. : 27°CDB, 19.0°CWB / outdoor temp.: 35°CDB / Equivalent piping length: 7.5m, level difference: 0m.
- ★3 Indoor temp. : 20°CDB / outdoor temp.: 7°CDB, 6°CWB / Equivalent piping length; 7.5m, level difference; 0m. (Heat pump only)
- ★4 Static external pressure is changeable to change over the connectors inside electrical box, this pressure means "High static pressure-Standard -Low static pressure".
- ★5 Static external pressure is changeable to change over the connectors inside electrical box, this pressure means "High static pressure-Standard".
- 6 Capacities are net, including a deduction for cooling (an additional for heating) for indoor fan motor heat.
- ★7 Anechoic chamber conversion value, measured at a point 1.5m downward from the unit center. These values are normally somewhat higher during actual operation as a result of ambient conditions.
- 8 Refer to page 208 for Fan Motor Input.

Conversion Formulae
kcal/h=kW×860
Btu/h=kW×3414
cfm=m <sup>3</sup> /min×35.3

**FXSQ40M + BYBS45DJW1 (With Canvas Duct)**  
**FXSQ50M + BYBS45DJW1 (With Canvas Duct)**

Unit(mm)

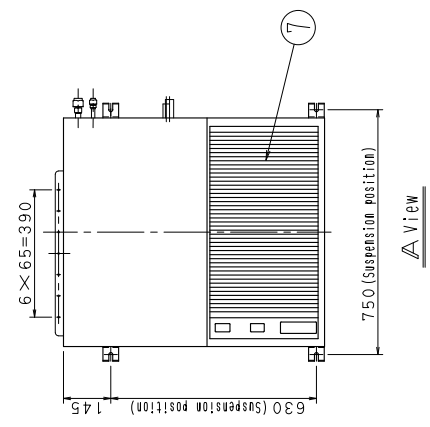
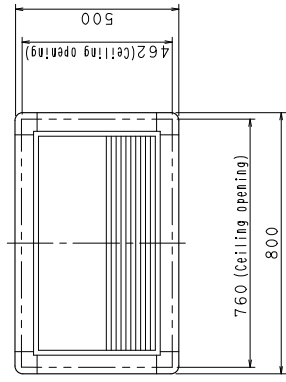
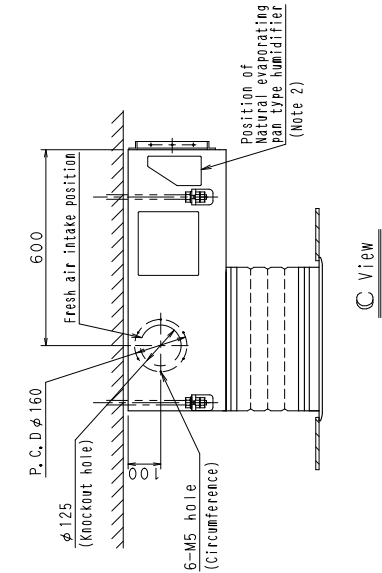
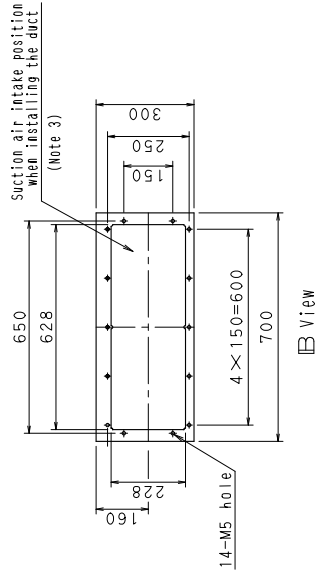
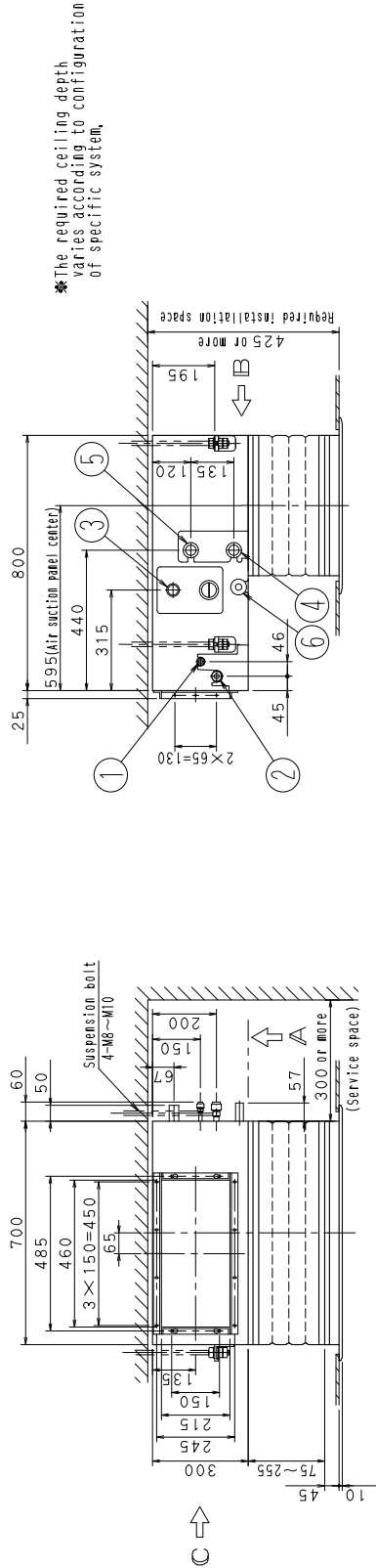

- Notes:
1. Location of unit's Name Plate: fan housing surface inside of filter.
  2. When installing an optional accessory, refer to the installation drawings.
  3. Refer to the separate drawing when installing the duct.
  4. "Decoration panel" and "Air suction canvas" are optional accessories.

Number	Name	Description
1	Liquid pipe connection	φ6.4 flare connection
2	Gas pipe connection	φ12.7 flare connection
3	Drain pipe connection	VP25(O, D, φ32 I. D, φ25)
4	Interunit wiring port	
5	Power wiring port	
6	Drain hole	VP25(O, D, φ32 I. D, φ25)
7	Air filter	

3D039438

FXSQ63M + BYBS71DJW1 (with Canvas Duct)

Unit(mm)

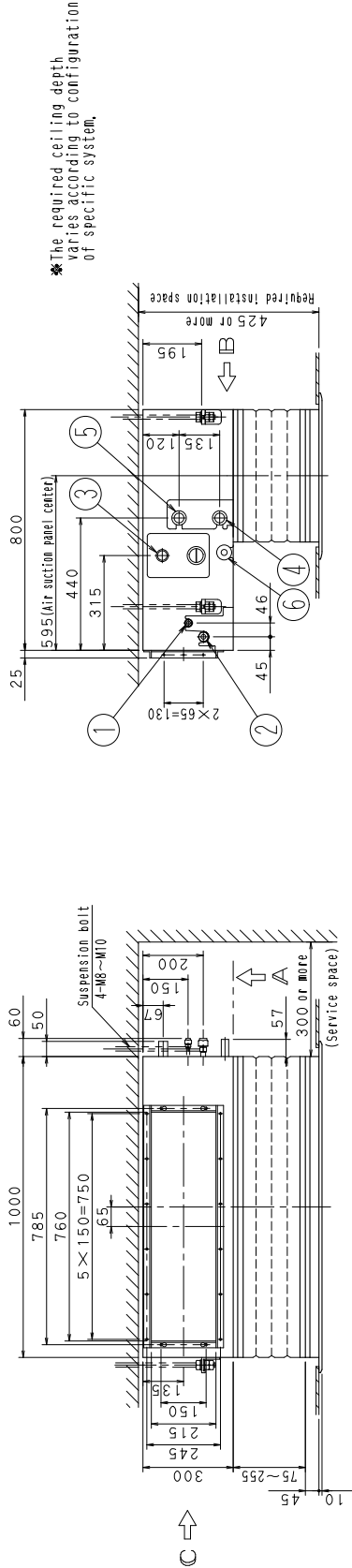

\*The required ceiling depth varies according to configuration of specific system.

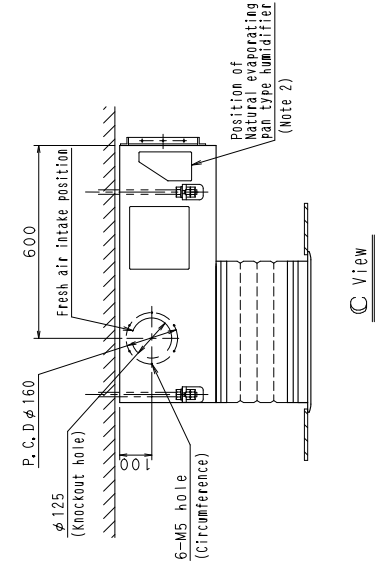
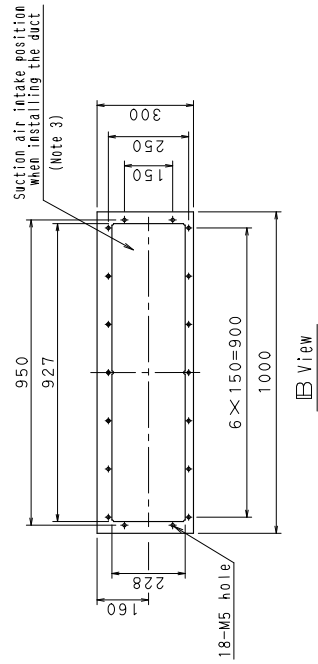

- Notes:
1. Location of unit's Name Plate: Fan housing surface inside of filter.
  2. When installing an optional accessory, refer to the installation drawings.
  3. Refer to the separate drawing when installing the duct, 'Decoration panel' and 'Air suction canvas' are optional accessories.

Number	Name	Description
1	Liquid pipe connection	φ9.5 flare connection
2	Gas pipe connection	φ15.9 flare connection
3	Drain pipe connection	VP25(O.D. φ32 I.D. φ25)
4	Interunit wiring port	
5	Power wiring port	
6	Drain hole	VP25(O.D. φ32 I.D. φ25)
7	Air filter	

3D039439